

496

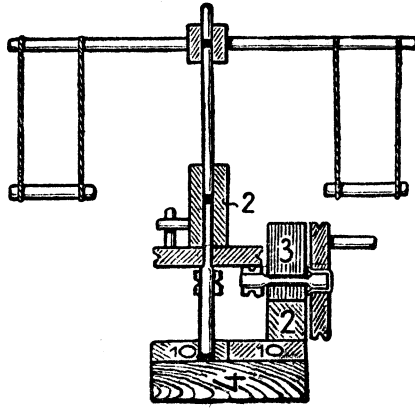

174/2

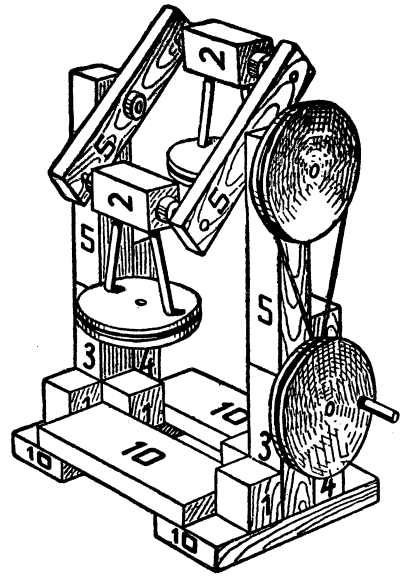

178

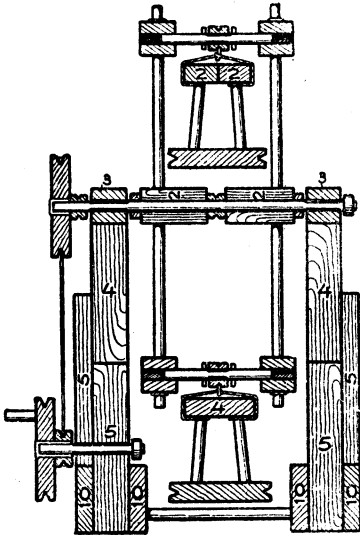

496/2

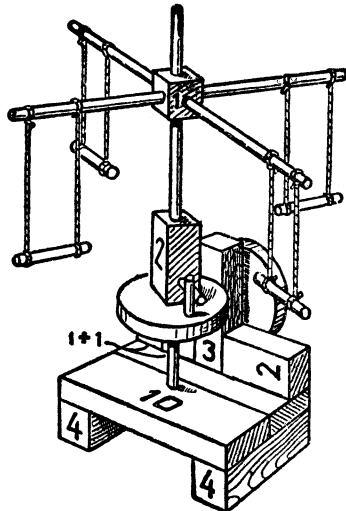

174

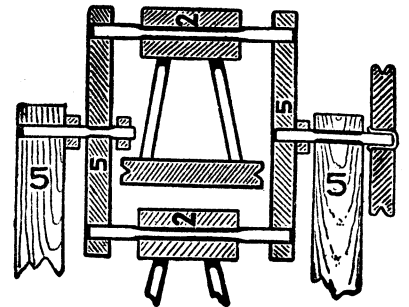

178/2

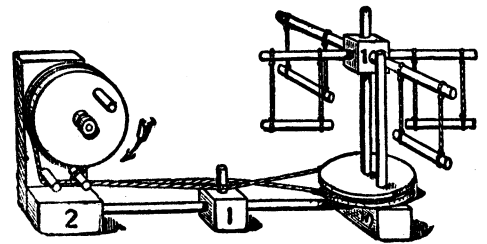

175

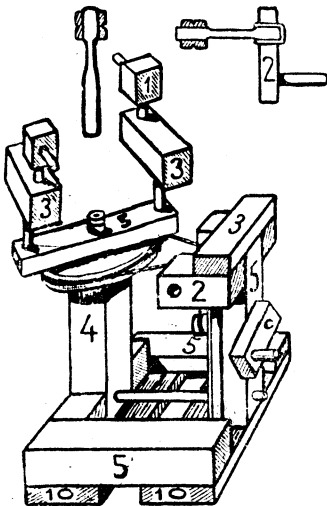

205

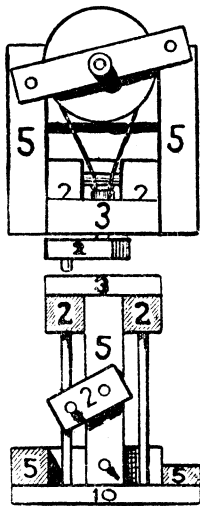

205/2

